

# INNOLUX DISPLAY CORPORATION

## LCD MODULE

# SPECIFICATION

Customer: \_\_\_\_\_

Model Name: AT070TN01 V.2

SPEC NO.: A070-01-TT-01

Data: 2005/06/28

Version: 1

Preliminary Specification

Final Specification

For Customer's Acceptance

Approved by	Comment

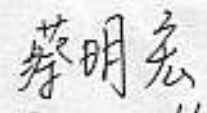
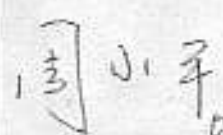
Approved by	Reviewed by	Prepared by
 2005/06/29 14191	 蔡明宏 6/29/05	 13 小平 06/29/05

## Record of Revision

Version	Revise Date	Page	Content
1	2005/06/28		Initial Release

**Contents:**

1.	General Specifications .....	1
2.	Pin Assignment .....	2
2.1.	TFT LCD Panel Driving Section .....	2
2.2.	Backlight Unit Section .....	4
3.	Operation Specifications .....	5
3.1.	Absolute Maximum Rating .....	5
3.2.	Electrical Characteristics .....	6
3.2.1.	Typical Operation Conditions.....	6
3.2.2.	Current Consumption .....	7
3.2.3.	Backlight Driving Condition.....	7
3.3.	Timing Characteristics.....	8
3.3.1.	Timing Conditions.....	8
3.3.2.	Timing Diagram .....	10
4.	Optical Specifications.....	14
5.	Reliability Test Items .....	18
6.	Handling Precautions.....	20
6.1.	Safety .....	20
6.2.	Handling.....	20
6.3.	Static Electricity .....	20
6.4.	Storage.....	20
6.5.	Cleaning.....	20
7.	Mechanical Drawing.....	21
8.	Package Drawing.....	22
8.1.	Packaging Material Table .....	22
8.2.	Packaging Quantity .....	22
8.3.	Packaging Drawing .....	23

# 1. General Specifications

No.	Item	Specification	Remark
1	LCD size	7.0 inch	
2	Driver element	a-Si TFT active matrix	
3	Resolution	480X3(RGB)X234	
4	Display mode	Normally White, Transmissive	
5	Dot pitch	0.107(W)X0.370(H) mm	
6	Active area	154.08(W)X86.58(H) mm	
7	Module size	164.9(W)X100.0(H)X5.7(D) mm	Note 1
8	Surface treatment	Anti-Glare	
9	Color arrangement	RGB-stripe	
10	Interface	Analog	
11	Power Consumption	3.47 W	
12	Weight	157 g	

Note 1: Refer to Mechanical Drawing.

## 2. Pin Assignment

### 2.1. TFT LCD Panel Driving Section

Pin No.	Symbol	I/O	Function	Remark
1	GND	-	Ground	
2	V <sub>CC</sub>	P	Supply voltage for logic control circuit scan driver	
3	V <sub>GL</sub>	P	Negative power for scan driver	
4	V <sub>GH</sub>	P	Positive power for scan driver	
5	STVR	I/O	Vertical start pulse	Note 1
6	STVL	I/O	Vertical start pulse	Note 1
7	CKV	I	Shift clock input for scan driver	
8	U/D	I	UP/DOWN scan control input	Note 1, 2
9	OEV	I	Output enable control for scan driver	
10	V <sub>COM</sub>	I	Common electrode driving signal	
11	V <sub>COM</sub>	I	Common electrode driving signal	
12	L/R	I	LEFT/RIGHT scan control input	Note 1, 2
13	MOD	I	Sequential sampling and simultaneous sampling setting	
14	OEH	I	Output enable control for data driver	
15	STHL	I/O	Start pulse for horizontal scan line	Note 1
16	STHR	I/O	Start pulse for horizontal scan line	Note 1
17	CPH3	I	Sampling and shifting clock pulse for data driver	
18	CPH2	I	Sampling and shifting clock pulse for data driver	
19	CPH1	I	Sampling and shifting clock pulse for data driver	
20	V <sub>CC</sub>	P	Supply voltage for logic control circuit scan driver	

21	GND	-	Ground	
22	V <sub>R</sub>	I	Alternated video signal (Red)	
23	V <sub>G</sub>	I	Alternated video signal (Green)	
24	V <sub>B</sub>	I	Alternated video signal (Blue)	
25	AV <sub>DD</sub>	P	Supply voltage for analog circuit	
26	AV <sub>SS</sub>	P	Ground for analog circuit	

Note 1: Selection of scanning mode

Setting of scan control input		IN/OUT state for start pulse				Scanning direction
U/D	L/R	STVR	STVL	STHR	STHL	
GND	V <sub>CC</sub>	O	I	O	I	Up to down, left to right
V <sub>CC</sub>	GND	I	O	I	O	Down to up, right to left
GND	GND	O	I	I	O	Up to down, right to left
V <sub>CC</sub>	V <sub>CC</sub>	I	O	O	I	Down to up, left to right

I: input, O: output

Note 2: Definition of Scanning Direction.

Refer to the figure as below:

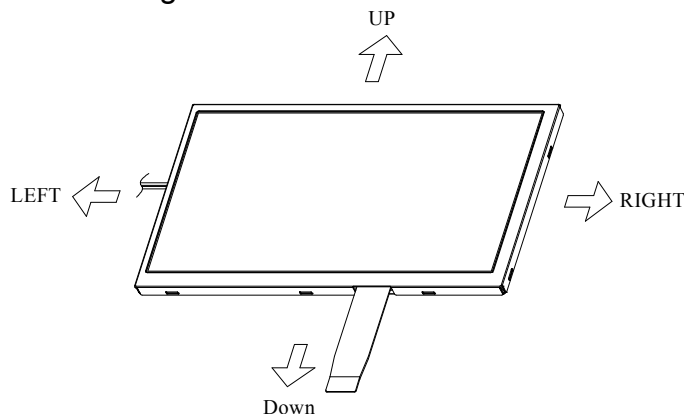

Note 3: MOD=H: Simultaneous sampling.

MOD=L: Sequential sampling.

Please set CPH2 and CPH3 to GND when MOD=H.

## 2.2. Backlight Unit Section

Pin No.	Symbol	I/O	Function	Remark
1	HI	P	Power supply for backlight unit(High voltage)	Pink
2	GND	-	Ground for backlight unit	White

### 3. Operation Specifications

#### 3.1. Absolute Maximum Rating

(GND=AV<sub>SS</sub>=0V, Note 3)

Item	Symbol	Values		Unit	Remark
		Min.	Max.		
Power voltage	V <sub>CC</sub>	-0.3	7	V	
	AV <sub>DD</sub>	-0.3	7	V	
	V <sub>GH</sub>	-0.3	18	V	
	V <sub>GL</sub>	-15	0.3	V	
	V <sub>GH</sub> -V <sub>GL</sub>	-	33	V	
Input signal voltage	V <sub>i</sub>	-0.2	AV <sub>DD</sub> +0.2	V	Note 1
	V <sub>I</sub>	-0.3	V <sub>CC</sub> +0.3	V	Note 2
Operation Temperature	T <sub>OP</sub>	-20	70	°C	
Storage Temperature	T <sub>ST</sub>	-30	80	°C	

Note 1: V<sub>R</sub>, V<sub>G</sub>, V<sub>B</sub>.

Note 2: STHL, STHR, OEH, L/R, CPH1~CPH3, STVR, STVL, OEV, CKV, U/D.

Note 3: The absolute maximum rating values of this product are not allowed to be exceeded at any times. The module should be used with any of the absolute maximum ratings exceeded, the characteristics of the module may not be recovered, or in an extreme case, the module may be permanently destroyed.



## 3.2. Electrical Characteristics

### 3.2.1. Typical Operation Conditions

 (GND=AV<sub>SS</sub>=0V, Note 4)

Item	Symbol	Values			Unit	Remark
		Min.	Typ.	Max.		
Power voltage	V <sub>CC</sub>	4.8	5	5.2	V	
	AV <sub>DD</sub>	4.8	5	5.2	V	
	V <sub>GH</sub>	14.3	15	15.7	V	
	V <sub>GL</sub>	-10.5	-10	-9.5	V	
Video signal amplitude (VR, VG, VB)	V <sub>iA</sub>	0.2	-	AV <sub>DD</sub> - 0.2	V	Note 1
	V <sub>iAC</sub>	-	3	-	V	AC component
	V <sub>iDC</sub>	-	AV <sub>DD</sub> /2	-	V	DC component
V <sub>COM</sub>	V <sub>CAC</sub>	3.5	5.6	6.5	V	Note 2
	V <sub>CDC</sub>	1.55	1.75	1.95	V	DC component
Input logic high voltage	V <sub>IH</sub>	0.8V <sub>CC</sub>	-	V <sub>CC</sub>	V	Note 3
Input logic low voltage	V <sub>IL</sub>	0	-	0.2V <sub>CC</sub>	V	

Note 1: Refer to Fig.3-3-(a).

Note 2: The brightness of LCD panel could be changed by adjusting the AC component of V<sub>COM</sub>.

Note 3: STHL, STHR, OEH, L/R, CPH1~CPH3, STVR, STVL, OEV, CKV, U/D.

Note 4: Be sure to apply GND, V<sub>CC</sub>, and V<sub>GL</sub>, to the LCD first, and then apply V<sub>GH</sub>.

### 3.2.2. Current Consumption

 (GND=AV<sub>SS</sub>=0V)

Item	Symbol	Values			Unit	Remark
		Min.	Typ.	Max.		
Current for Driver	I <sub>GH</sub>	-	0.2	0.5	mA	V <sub>GH</sub> =15V
	I <sub>GL</sub>	-	0.8	1.5	mA	V <sub>GL</sub> = -10V
	I <sub>CC</sub>	-	3.0	6.0	mA	V <sub>CC</sub> =5V
	I <sub>DD</sub>	-	17	30	mA	AV <sub>DD</sub> =5V

### 3.2.3. Backlight Driving Condition

Item	Symbol	Values			Unit	Remark
		Min.	Typ.	Max.		
Lamp voltage	V <sub>L</sub>	-	560	620	V <sub>rms</sub>	Note 1,6
Lamp current	I <sub>L</sub>	-	6	7	mA <sub>rms</sub>	Note 6
Frequency	F <sub>L</sub>	-	60	80	kHz	Note 3
Lamp starting voltage	V <sub>S</sub>	-	-	900	V <sub>rms</sub>	Note 1,4,6
		-	-	-	V <sub>rms</sub>	Note 2,4,6
Lamp life time	-	10,000	-	-	Hr	Note 5

Note 1: The ambient temperature is 25°C.

Note 2: The ambient temperature is 0°C.

Note 3: The lamp frequency should be selected as different as possible from display horizontal synchronous signal to avoid interference.

Note 4: For starting the backlight unit, the output voltage of DC/AC's transformer should be larger than the maximum lamp starting voltage.

Note 5: The "lamp life time" is defined as the module brightness decrease to 50% original brightness that the ambient temperature is 25°C and I<sub>L</sub> =6mA.

Note 6: Measure inverter type: HIU-742A, C=11pF, Input Voltage=12.0V<sub>dc</sub>.

### 3.3. Timing Characteristics

#### 3.3.1. Timing Conditions

Item	Symbol	Values			Unit	Remark
		Min.	Typ.	Max.		
Rising time	$t_r$	-	-	10	ns	Note 1
Falling time	$t_f$	-	-	10	ns	Note 1
High and low level pulse width	$t_{CPH}$	99	103	107	ns	CPH1~CPH3
CPH pulse duty	$t_{CWH}$	40	50	60	%	CPH1~CPH3
CPH pulse delay	$t_{C12}$	30	$t_{CPH}/3$	$t_{CPH}/2$	ns	CPH1~CPH3
	$t_{C23}$					
	$t_{C31}$					
STH setup time	$t_{SUH}$	20	-	-	ns	STHR, STHL
STH hold time	$t_{HDH}$	20	-	-	ns	STHR, STHL
STH pulse width	$t_{STH}$	-	1	-	$t_{CPH}$	STHR, STHL
STH period	$t_H$	61.5	63.5	65.5	$\mu s$	STHR, STHL
OEH pulse width	$t_{OEH}$	-	1.22	-	$\mu s$	
Sample and hold disable time	$t_{DIS1}$	-	8.28	-	$\mu s$	
OEV pulse width	$t_{OEV}$	-	5.40	-	$\mu s$	
CKV pulse width	$t_{CKV}$	-	4.18	-	$\mu s$	
Clean enable time	$t_{DIS2}$	-	3.74	-	$\mu s$	
Horizontal display start	$t_{SH}$	-	0	-	$t_{CPH}/3$	
Horizontal display timing range	$t_{DH}$	-	1440	-	$t_{CPH}/3$	
STV setup time	$t_{SUV}$	400	-	-	ns	STVL, STVR
STV hold time	$t_{HDV}$	400	-	-	ns	STVL, STVR

STV pulse width	$t_{STV}$	-	-	1	$t_H$	STVL, STVR
Horizontal lines per field	$t_V$	256	262	268	$t_H$	Note 2
Vertical display start	$t_{SV}$	-	3	-	$t_H$	
Vertical display timing range	$t_{DV}$	-	234	-	$t_H$	
$V_{COM}$ rising time	$t_{rCOM}$	-	-	5	$\mu s$	
$V_{COM}$ falling time	$t_{fCOM}$	-	-	5	$\mu s$	
$V_{COM}$ delay time	$t_{DCOM}$	-	-	3	$\mu s$	
RGB delay time	$t_{DRGB}$	-	-	1	$\mu s$	

Note 1: For all of the logic signals

Note 2: Please don't use odd horizontal lines to drive LCD panel for both odd and even field simultaneously.

**3.3.2. Timing Diagram**

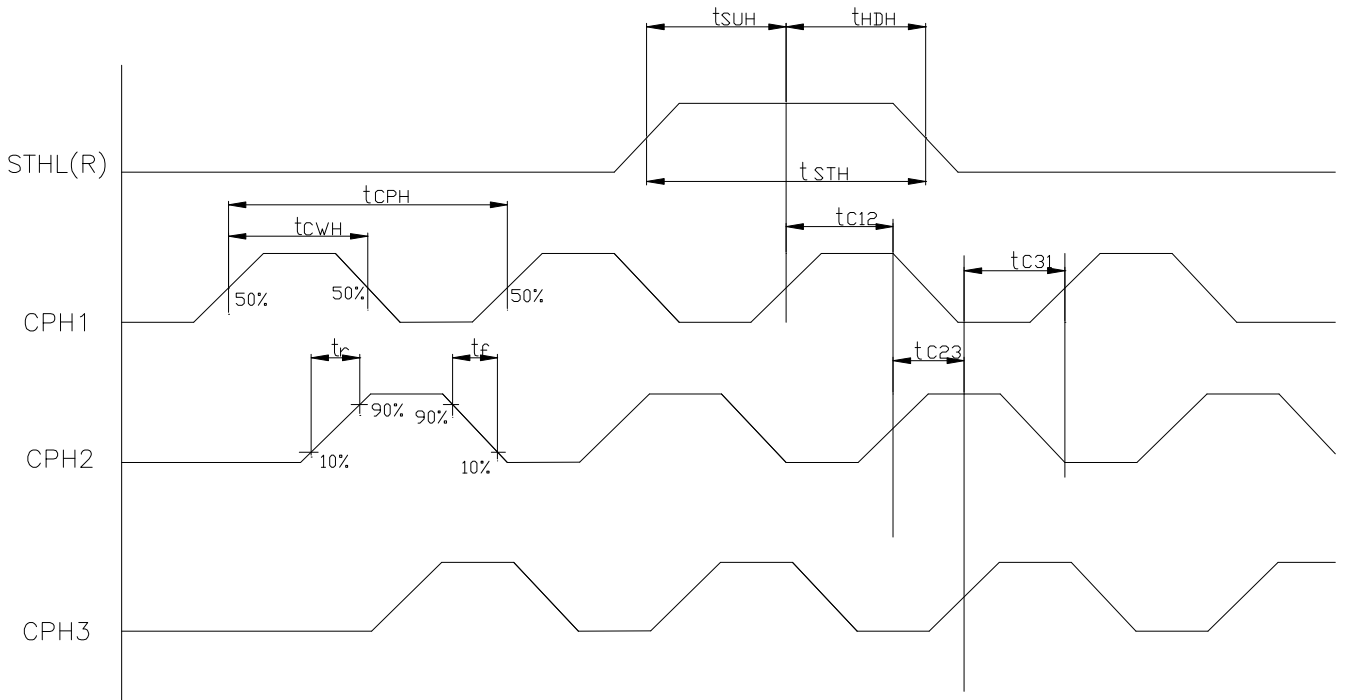

**Fig.3-1 Sampling clock timing**

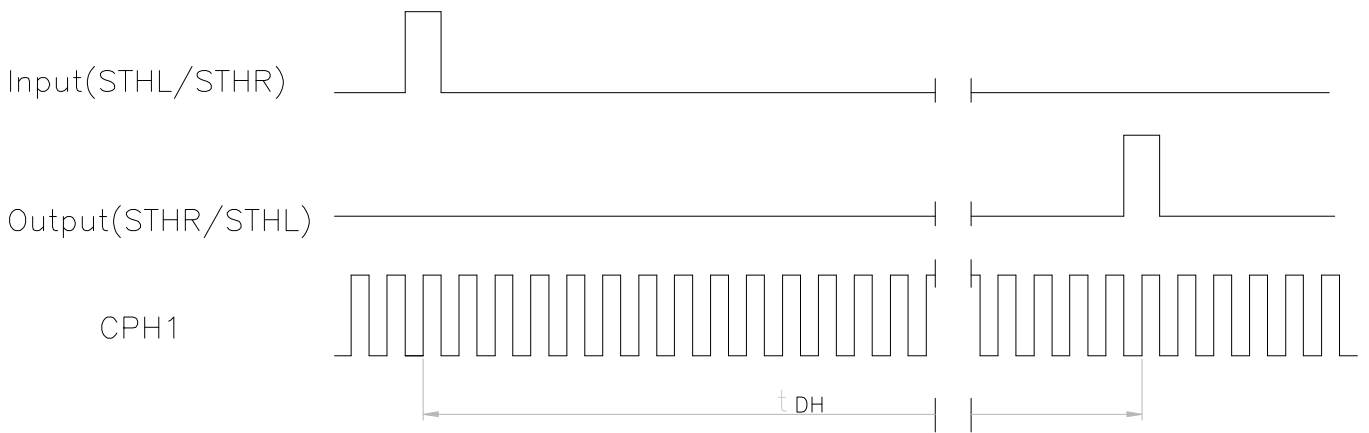

**Fig.3-2 Horizontal display timing range**

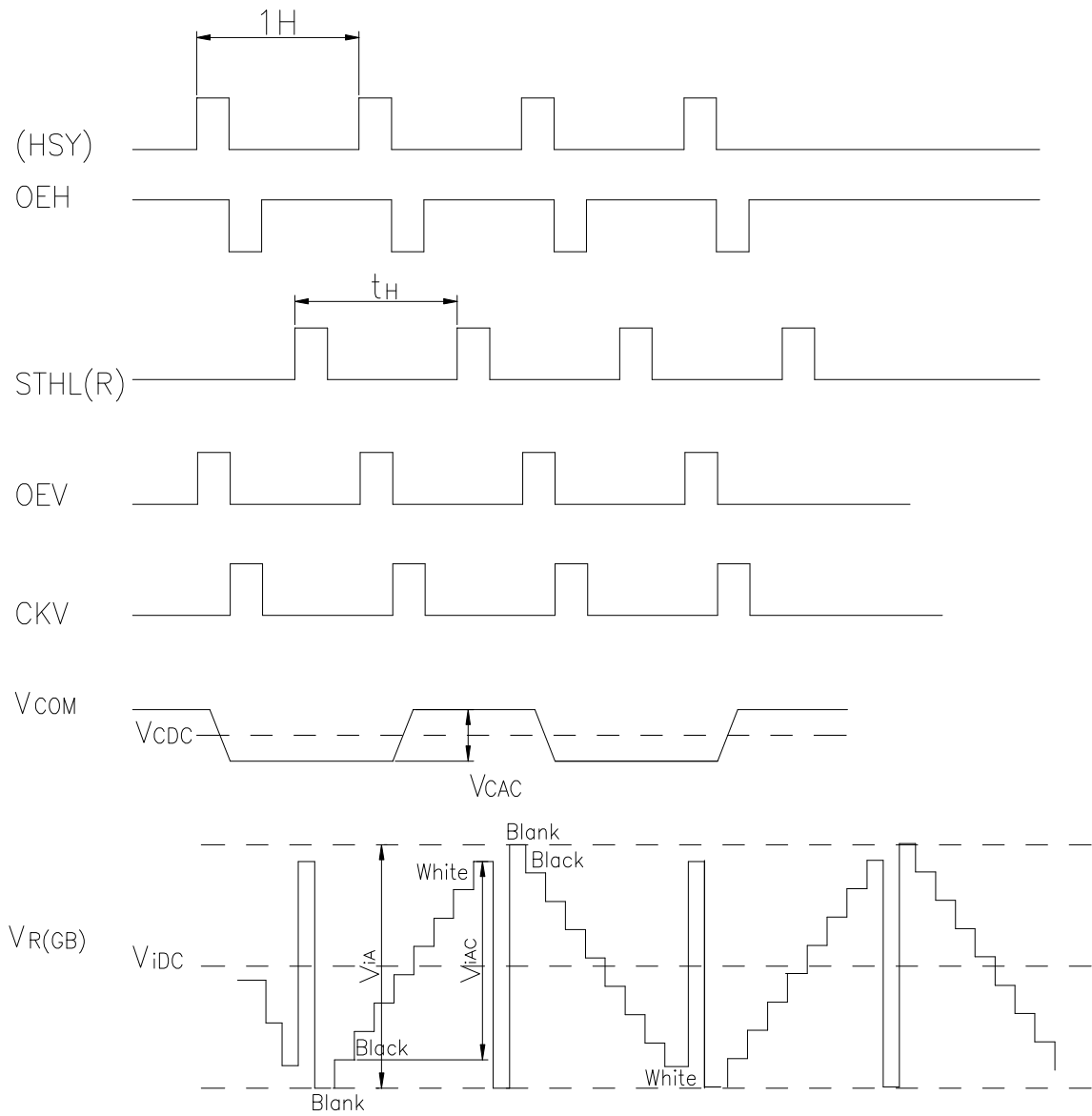

**Fig.3-3-(a) Horizontal timing**

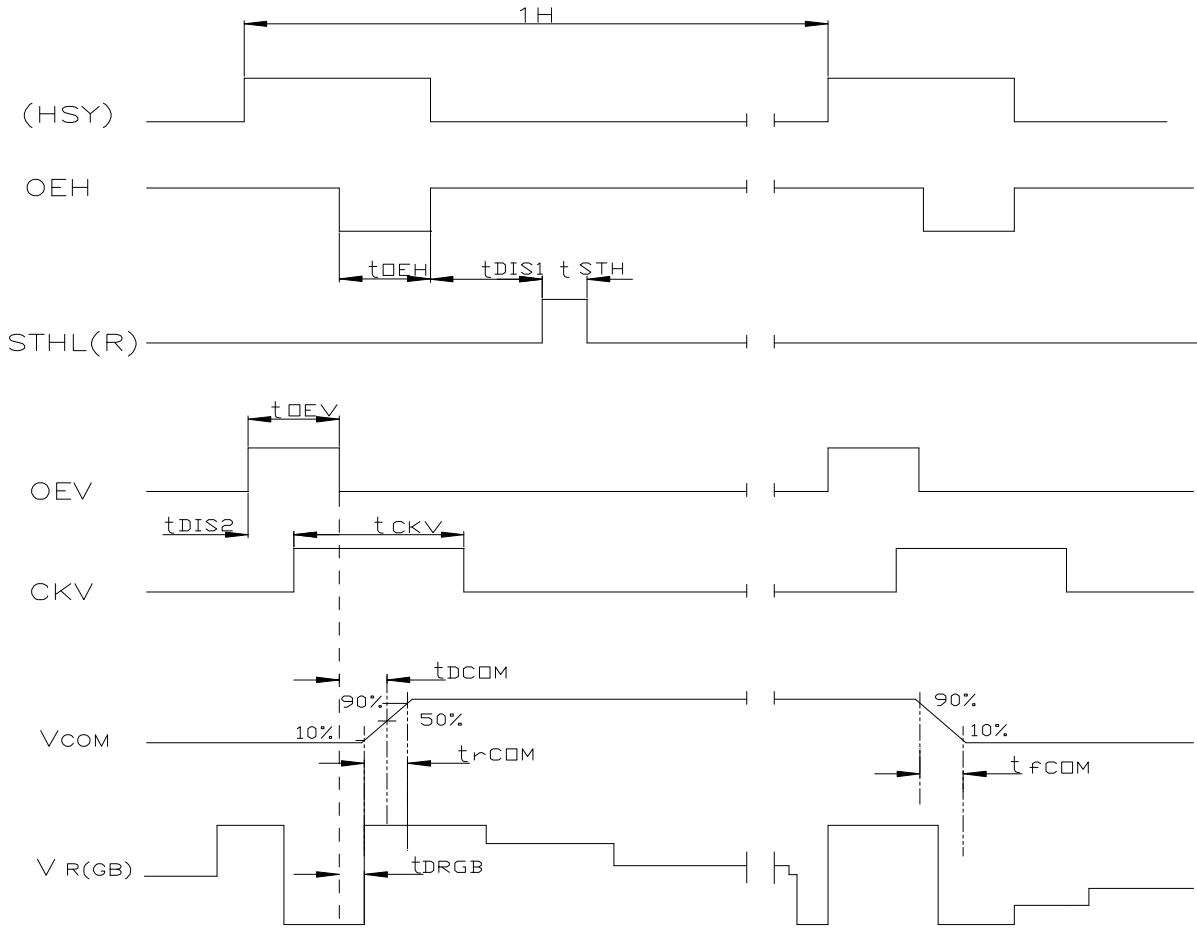

Note: The falling edge of OEV should be synchronized with the falling edge of OEH  
 Fig.3-3-(b) Detail horizontal timing

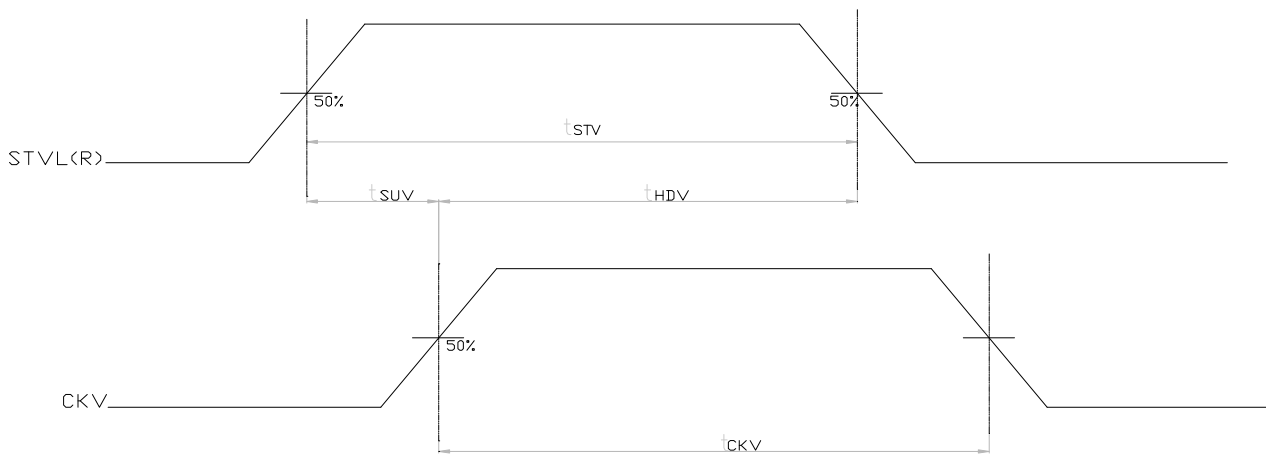

Fig.3-4 Vertical shift clock timing horizontal timing

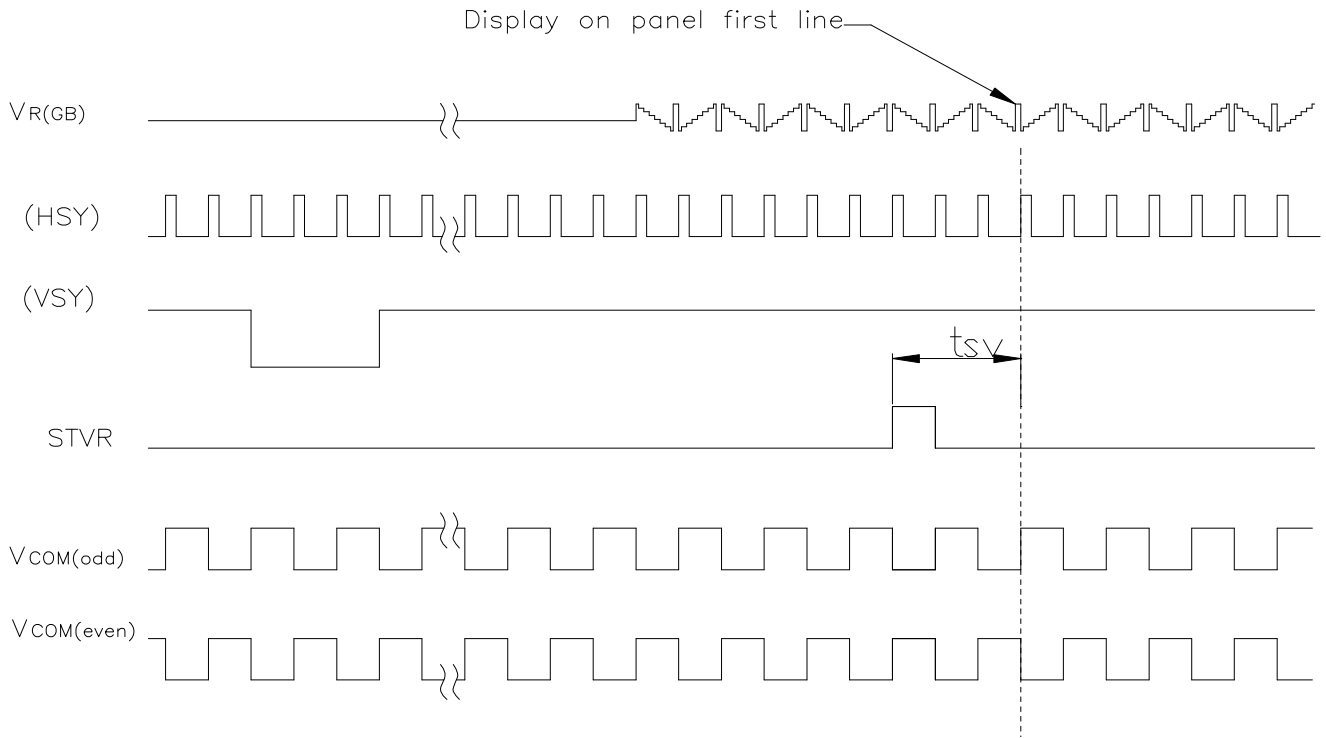

Fig.3-5(a) Vertical timing (from up to down)

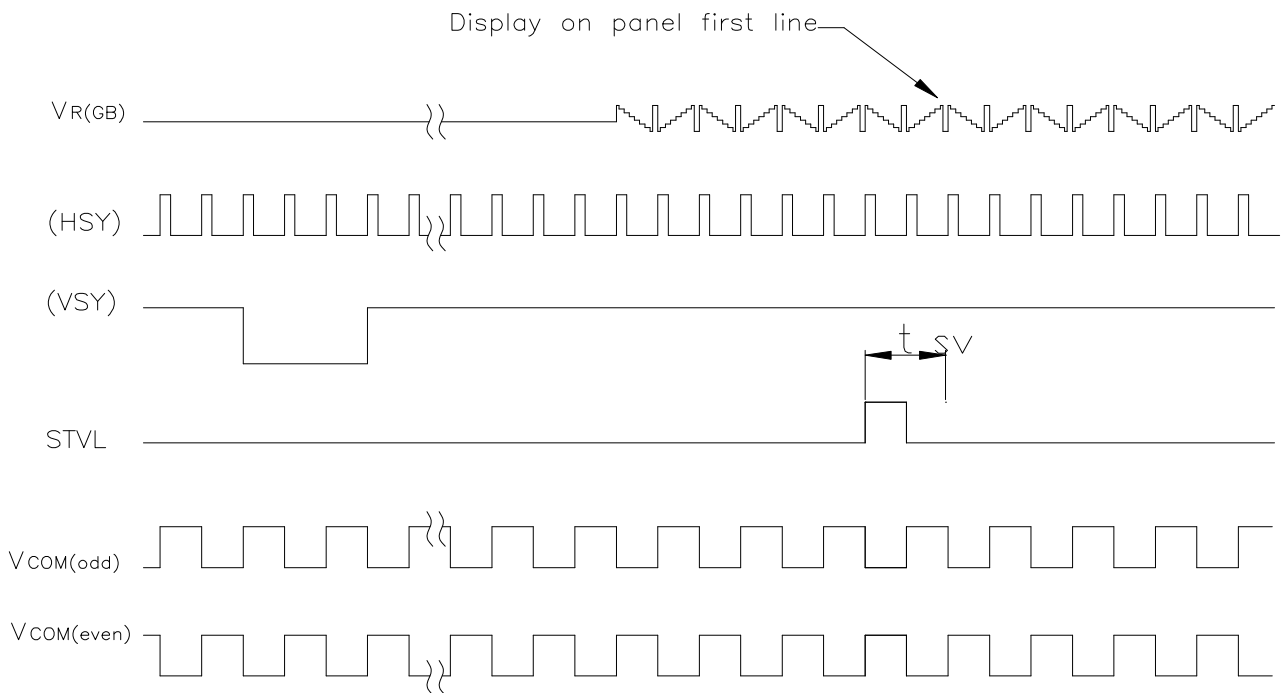

Fig.3-5(b) Vertical timing (from down to up)



## 4. Optical Specifications

Item	Symbol	Condition	Min.	Typ.	Max.	Unit	Remark
Viewing angle (CR≥10)	$\theta_L$	$\Phi=180^\circ$ (9 o'clock)	50	60	-	degree	Note 1
	$\theta_R$	$\Phi=0^\circ$ (3 o'clock)	50	60	-		
	$\theta_T$	$\Phi=90^\circ$ (12 o'clock)	30	40	-		
	$\theta_B$	$\Phi=270^\circ$ (6 o'clock)	50	60	-		
Response Time	$T_{ON}$	Normal $\theta=\Phi=0^\circ$	-	15	30	msec	Note 3
	$T_{OFF}$		-	20	40	msec	Note 3
Contrast ratio	CR		100	150	-	-	Note 4
Color chromaticity	$W_X$		0.26	0.31	0.36	-	Note 5 Note 6
	$W_Y$		0.28	0.33	0.38	-	
	$R_X$		0.47	0.52	0.57	-	
	$R_Y$		0.25	0.30	0.35	-	
	$G_X$		0.23	0.28	0.33	-	
	$G_Y$		0.50	0.55	0.60	-	
	$B_X$		0.10	0.15	0.20	-	
	$B_Y$	0.07	0.11	0.16	-		
Luminance	L	200	250	-	cd/m <sup>2</sup>	Note 6	
Luminance uniformity	$Y_U$	70	75	-	%	Note 7	

**Test Conditions:**

- $V_{CC}=5V$ ,  $AV_{DD}=5V$ ,  $I_L=6mA_{rms}$  (Backlight current), the ambient temperature is 25°C.
- The test systems refer to Note 2.

Note 1: Definition of viewing angle range

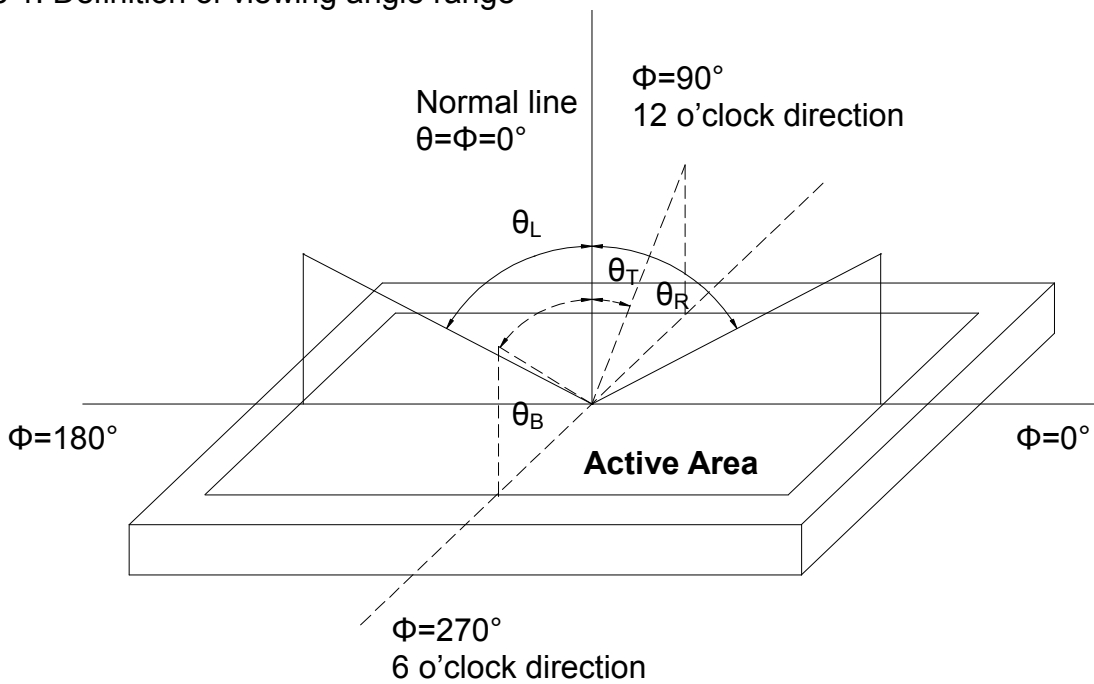

Fig. 4-1 Definition of viewing angle

Note 2: Definition of optical measurement system. (TFT)

The optical characteristics should be measured in dark room. After 30 minutes operation, the optical properties are measured at the center point of the LCD screen. (Response time is measured by Photo detector TOPCON BM-7, other items are measured by BM-5A/Field of view: 1° /Height: 500mm.)

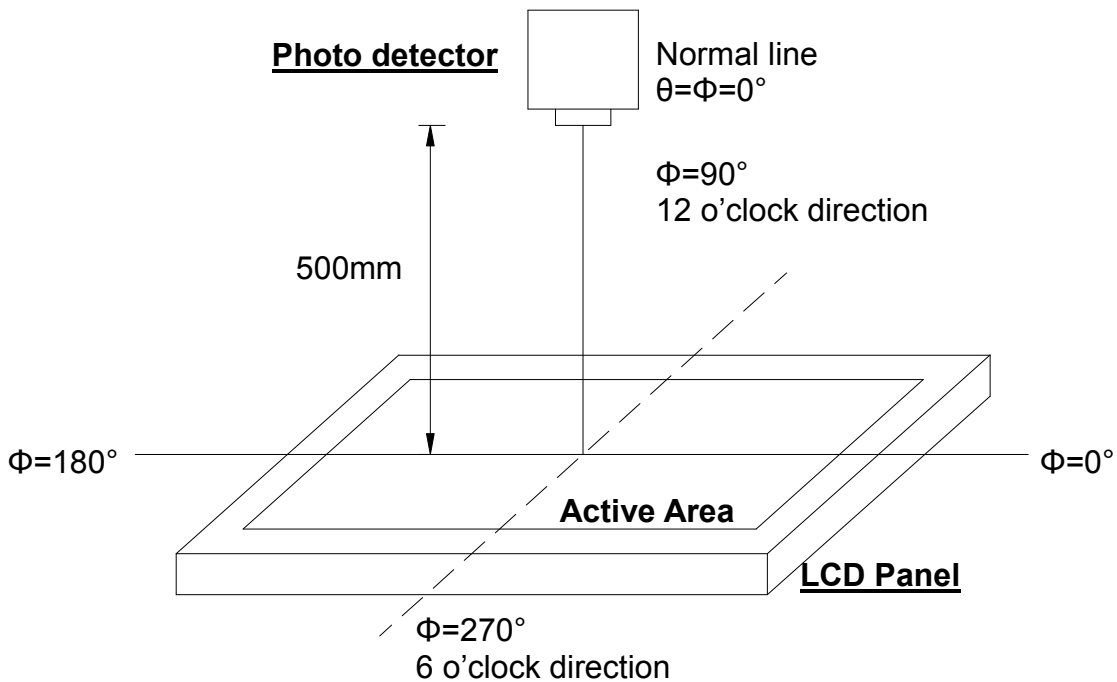

Fig. 4-2 Optical measurement system setup

**Note 3: Definition of Response time**

The response time is defined as the LCD optical switching time interval between “White” state and “Black” state. Rise time ( $T_{ON}$ ) is the time between photo detector output intensity changed from 90% to 10%. And fall time ( $T_{OFF}$ ) is the time between photo detector output intensity changed from 10% to 90%.

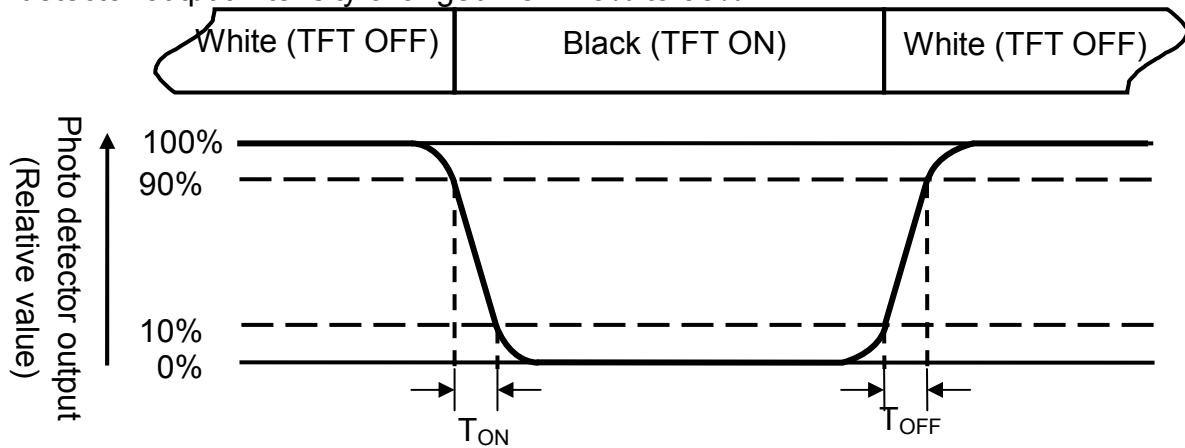

Fig. 4-3 Definition of response time

**Note 4: Definition of contrast ratio**

$$\text{Contrast ratio (CR)} = \frac{\text{Luminance measured when LCD is on the "White" state}}{\text{Luminance measured when LCD is on the "Black" state}}$$

White  $V_i = V_{i50\%} \pm 1.5 \text{ V}$

Black  $V_i = V_{i50\%} \mu 2.0 \text{ V}$

“ $\pm$ ” means that the analog input signal swings in phase with VCOM signal.

“ $\mu$ ” means that the analog input signal swings out of phase with VCOM signal.

$V_{i50\%}$ : The analog input voltage when transmission is 50%

The 100% transmission is defined as the transmission of LCD panel when all the input terminals of module are electrically opened.

**Note 5: Definition of color chromaticity (CIE1931)**

Color coordinates measured at center point of LCD.

**Note 6:** All input terminals LCD panel must be ground when measuring the center area of the panel.

Note 7: Definition of Luminance Uniformity

To test for uniformity, the tested area, which is inside the active area, is divided into 3 rows and 3 columns. The measurement spot is placed at the center of each box.

$$\text{Luminance Uniformity (Yu)} = \frac{B_{min}}{B_{max}}$$

L-----Active area length      W----- Active area width

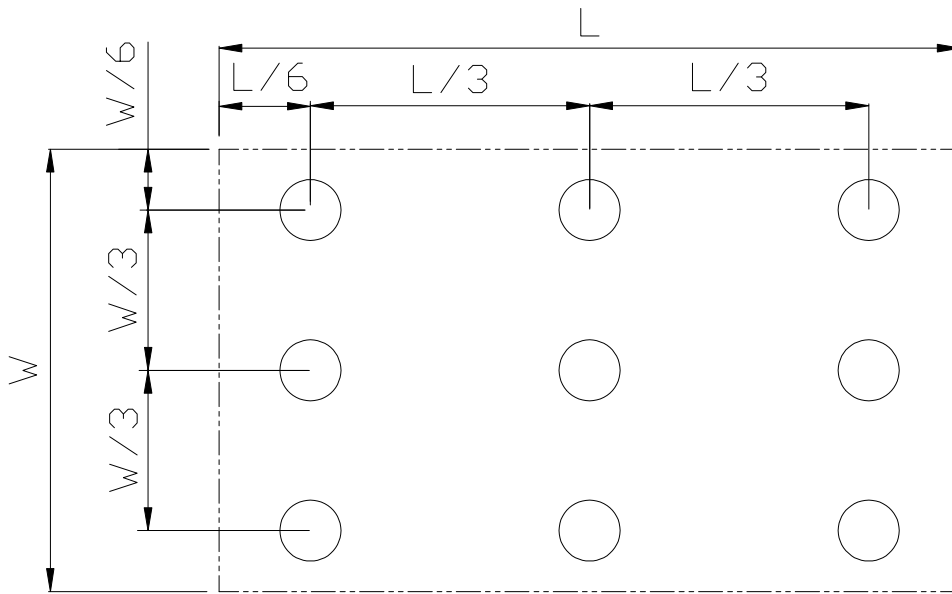

Fig. 4-4 Definition of uniformity

**B<sub>max</sub>**: The measured maximum luminance of all measurement position.

**B<sub>min</sub>**: The measured minimum luminance of all measurement position.

## 5. Reliability Test Items

Item	Test Conditions	Remark
High Temperature Storage	Ta = 80°C 240 hrs	Note 1
Low Temperature Storage	Ta = -30°C 240hrs	Note 1
High Temperature Operation	Ts = 70°C 240hrs	Note 2
Low Temperature Operation	Ta = -20°C 240hrs	Note 1
Operate at High Temperature and Humidity	+40°C, 90%RH max. 240 hrs	
Thermal Shock	-30°C/30 min ~ +80°C/30 min for a total 100 cycles, Start with cold temperature and end with high temperature	
Vibration Test	Frequency range:10~55Hz Stroke:1.5mm Sweep:10Hz~55Hz~10Hz 2 hours for each direction of X. Y. Z. (6 hours for total)	JIS C7021 A-10 Condition A
Mechanical Shock	100G 6ms,±X, ±Y, ±Z 3 times for each direction	JIS C7021 A-7 Condition C
Package Vibration Test	Random Vibration : 0.015G*G/Hz from 5-200HZ, -6dB/Octave from 200-500HZ 2 hours for each direction of X. Y. Z. (6 hours for total)	IEC 68-34
Package Drop Test	Height:60 cm 1 corner, 3 edges, 6 surfaces	JIS Z0202
Electro Static Discharge	± 2KV, Human Body Mode, 100pF/1500Ω	EIA/JESD22-A114

Note 1: Ta is the ambient temperature of samples.

Note 2:  $T_s$  is the temperature of panel's surface.  
 $T_s = (T_{s1} + T_{s2} + T_{s3} + T_{s4} + T_{s5}) / 5$ .

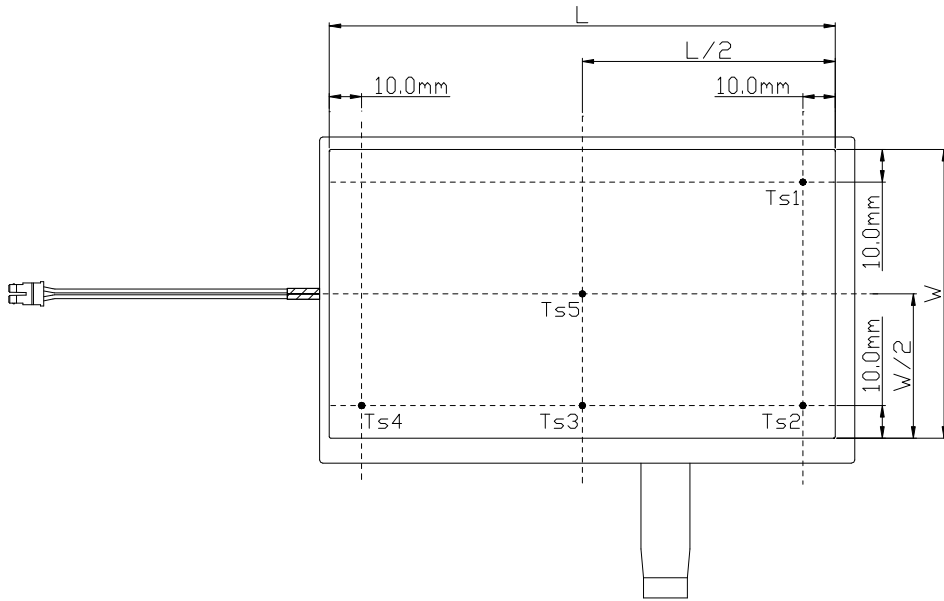

L is the length of Top Bezel open window,  
 W is the width of Top Bezel open window.

Note 3: In the standard condition, there shall be no practical problem that may affect the display function.

## 6. Handling Precautions

### 6.1. Safety

The liquid crystal in the LCD is poisonous. **DO NOT** put it in your mouth. If the liquid crystal touches your skin or clothes, wash it off immediately using soap and water.

### 6.2. Handling

1. The LCD panel is plate glass. **DO NOT** subject the panel to mechanical shock or to excessive force on its surface.
2. The polarizer attached to the display is very easy to damage, handle it with careful attention.
3. To avoid contamination on the display surface, **DO NOT** touch the display surface with bare hands.
4. Provide a space so that the LCD panel does not come into contact with other components.
5. To protect the LCD panel from external pressure, put covering glass (acrylic board or similar board) keeping appropriate gap between them.
6. Transparent electrodes may be disconnected if you use the LCD panel under environmental conditions where dew condensation occurs.
7. Property of semiconductor devices may be affected when they are exposed to light, possibly resulting in malfunctioning of the ICs.
8. To prevent such malfunctioning of the ICs, your design and mounting layout done are so that the IC is not exposed to light in actual use.

### 6.3. Static Electricity

1. Ground soldering iron tips, tools and testers when you operate.
2. Ground your body when handling the products.
3. **DO NOT** apply voltage to the input terminal without applying power supply.
4. **DO NOT** apply voltage which exceeds the absolute maximum rating.
5. Store the products in an anti-electrostatic container.

### 6.4. Storage

1. Store the products in a dark place at  $+25^{\circ}\text{C} \pm 10^{\circ}\text{C}$ , low humidity (65%RH or less).
2. **DO NOT** store the products in an atmosphere containing organic solvents or corrosive gases.

### 6.5. Cleaning

1. **DO NOT** wipe the polarizer with dry cloth, as it might cause scratch.
2. Wipe the polarizer with a soft cloth soaked with petroleum IPA, other chemical might damage.

# 7. Mechanical Drawing

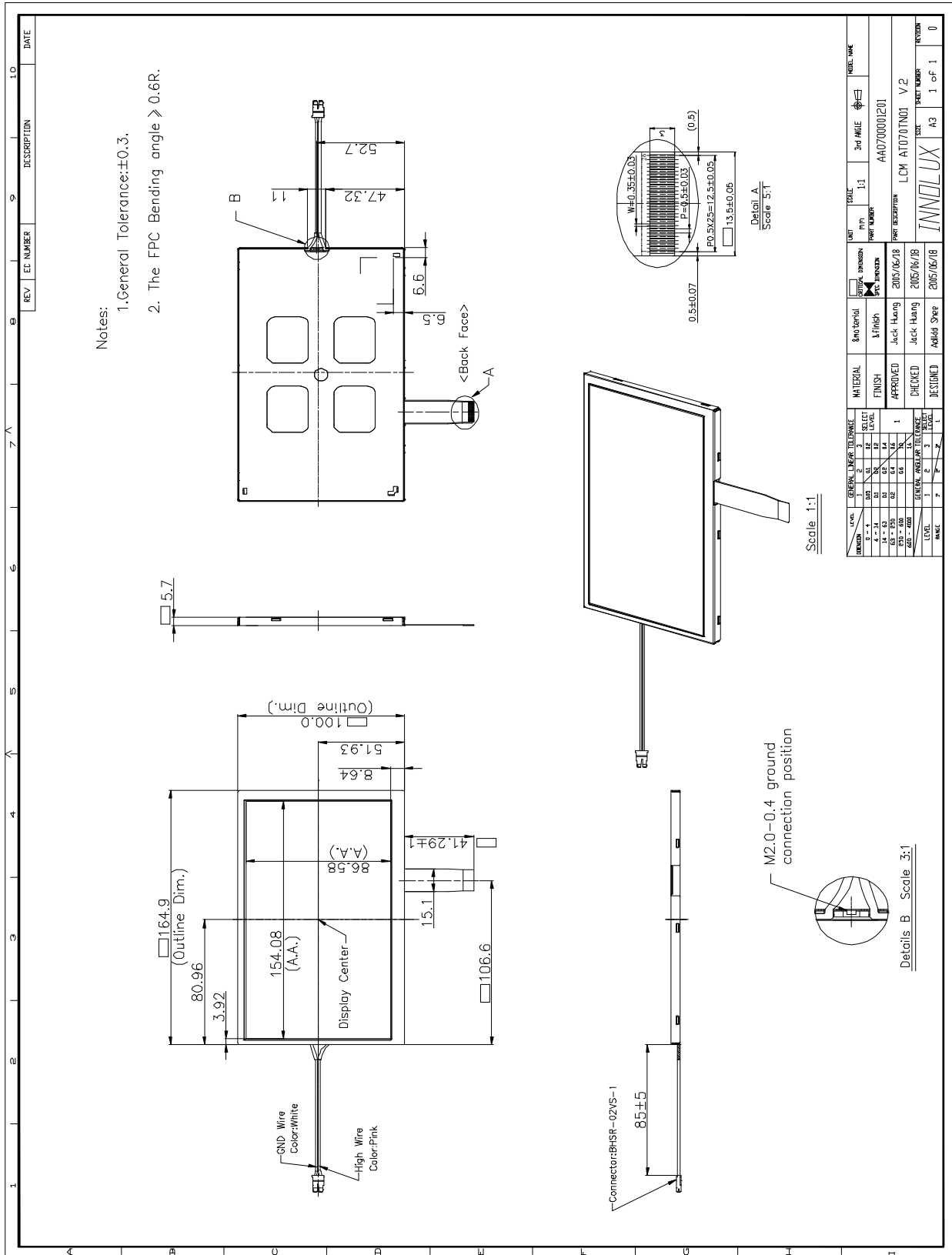



## 8. Package Drawing

### 8.1. Packaging Material Table

No.	Item	Model (Material)	Dimensions(mm)	Unit Weight (kg)	Quantity	Remark
1	LCM Module	AT070TN01 V.2	164.9×100×5.7	0.157	50 pcs	
2	Partition	BC Corrugated paper	512×349×226	1.466	1 set	
3	Corrugated Bar	B Corrugated paper	512X11X3	0.046	4 set	
4	Dust-Proof Bag	PE	700X530	0.048	1 pcs	
5	A/S Bag	PE	180×133×0.2	0.002	50 pcs	
6	Carton	Corrugated paper	530*355*255	1.100	1 pcs	
7	Total weight	10.65 ± 5%	Kg			

### 8.2. Packaging Quantity

Total LCM quantity in Carton: no. of Partition	2 Rows x	quantity per Row	25	= 50
--	----------	------------------	----	------

### 8.3. Packaging Drawing

